



## TECHNICAL SPECIFICATIONS

### Inspection unit

- Dimensions: 1524mm (L) x 770mm (W) x 1212mm (H)
- Weight: 300kg
- Tunnel size: 506mm (W) x 360mm (H)
- Conveyor belt height: 690mm (adjustable)
- Belt speed: 0.2m/s
- Maximum bag weight: 165kg
- 1 LCD widescreen monitor
- Power supply: Monophase 230VAC +/- 10%
- Frequency: 50/60Hz +/- 3Hz
- Power absorption: 1kVA
- Duty cycle: 100%

### X-Ray generator

- High frequency monobloc
- Tube voltage: 150kV
- Tube current: 0.5mA
- Beam orientation: Diagonal upwards

### Environmental compliance

- Operational temperatures: 0°C to 40°C
- Storage temperature: -20°C to +60°C
- Humidity: 95% without condensation

- Protection class: IP22
- Noise level: < 60dB

### Detection characteristics

- Resolution: 38 AWG
- Penetration: 27mm steel guaranteed, 30mm steel typical
- 768 detectors in two "L"-shaped rows of photodiodes

### Health and Safety

- The system fully meets the applicable international regulations for X-Ray equipment
- Leakage dose at 10cm: < 1.0 $\mu$ Sv/h (0.1mR/h)
  - Film safety: guaranteed up to ISO 1600/33 DIN

### Options

- NetServer
- Digital image archiving (AIMS)
- AIMS Networking
- Modular roller tables
- Remote workstation(s)
- UPS
- Smart-card login

REFERENCE REGULATION: EC, IEC, TSA, STAC, DfT, ENAC

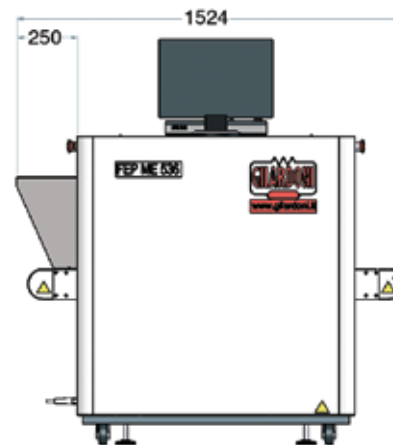
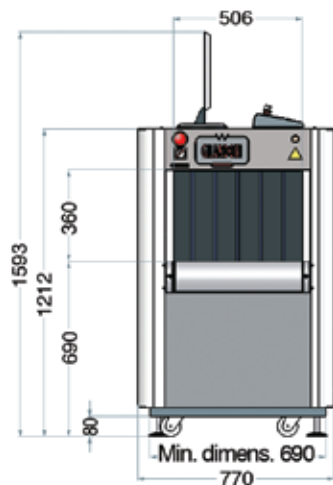

Dimensions in mm